



QUALITY... PLAIN & SIMPLE®

1955-1957 Chevy Brake and Clutch Pedal Installation Instructions

General Installation Notes:

Please read these instructions completely before beginning the installation. If you have any questions, please call.

Before beginning the installation, disconnect the negative battery cable and use wheel chocks to block the vehicle's wheels.

We recommend applying anti-seize lubricant to all aluminum threads before final assembly.

Brake Pedal Only (without Clutch Pedal):

Refer to Fig. 1 for the component names.

Step 1: Remove the existing pedal(s) following the steps outlined in the factory service manual for your particular model of car.

Step 2: Test-fit the original brake pedal axle into the new Lokar brake pedal before attempting installation. Due to manufacturing tolerances and possible differences between OE and replacement parts, some brake pedal axles may be too tight. If the brake pedal axle does not fit or will not turn freely inside the new Lokar pedal, call Lokar at 1-877-469-7440 for assistance.

Step 3: Lubricate the inside of the Delrin® spacers and the outside of your original brake pedal axle with a thin film of grease.

Position the wide Delrin® spacer inside the brake pedal return spring. Hook the "J" shaped arm of the brake pedal return spring into the notch on the firewall side of the brake pedal. Fig. 2 Position the brake pedal, the return spring, and the wide Delrin® spacer up into the pedal support bracket, forward (towards the firewall) of the hole in the pedal support bracket. The "L" shaped arm of the brake pedal return spring will hook under the edge of the pedal support bracket.

Rotate the top of the pedal and the return spring back (towards the steering wheel), while sliding the left end of the brake pedal return spring along the edge of the pedal support bracket. When the hole in the wide Delrin® spacer aligns with the hole in the pedal support bracket, insert your original brake pedal axle through the left side of the pedal support bracket, through the wide Delrin® spacer, and into the new brake pedal.

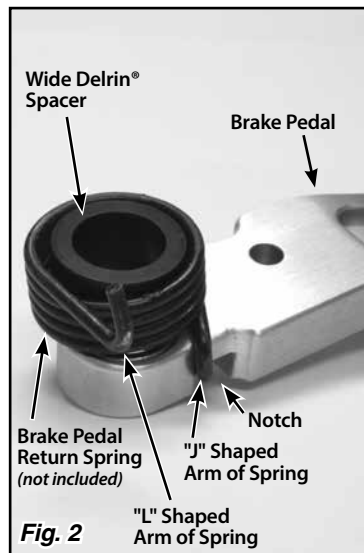

Fig. 2

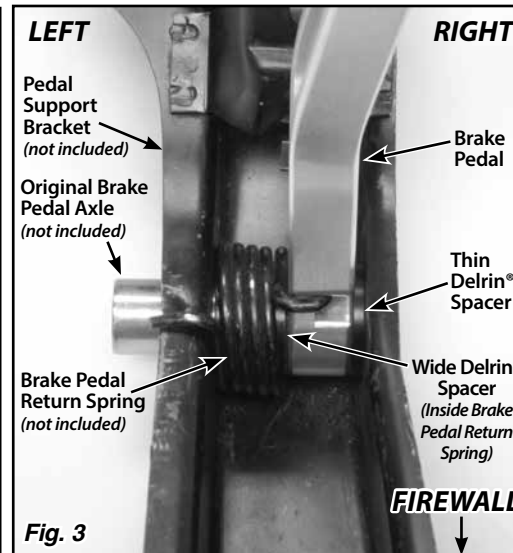

Fig. 3

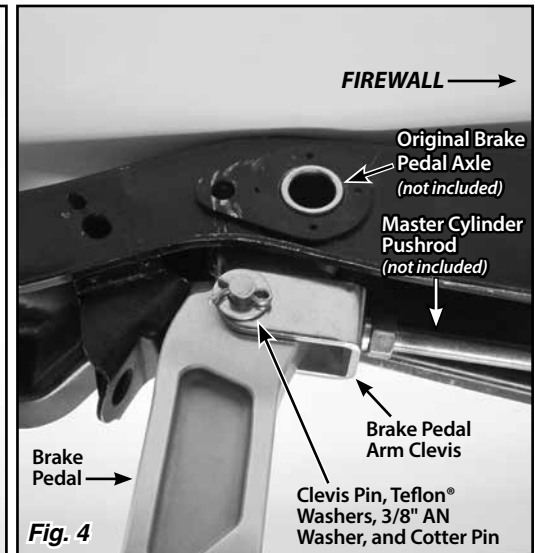

Fig. 4

1955-1957 Chevy Brake and Clutch Pedal Installation Instructions

Building American Quality... With A Lifetime Warranty!®

TOLL FREE 1-877-469-7440 • tech@lokar.com • www.lokar.com

Step 4: Use a large screwdriver or small pry bar to pry the top of the pedal to the left, and insert the thin Delrin® spacer into the gap between the top of the brake pedal and the right side of the pedal support bracket. Push the original brake pedal axle through the thin Delrin® spacer, and through the right side of the pedal support bracket. Fig. 3

Step 5: Install the original 5/16" bolt through the flange on the left side of the original pedal axle and the pedal support bracket, and secure with the original lock washer and nut.

Step 6: Remove the original clevis from your brake master cylinder pushrod. Install the new brake pedal arm clevis onto your original master cylinder pushrod.

Step 7: Raise the master cylinder pushrod with the new brake pedal arm clevis up into position on the brake pedal. Insert the Teflon® washers on both the left and right sides of the pedal, between the pedal and the clevis. Install the 3/8" clevis pin. Install the 3/8" AN washer and cotter pin on the end of the 3/8" clevis pin. Fig. 4

Step 8: Adjust the master cylinder pushrod length. Follow the proper procedure for your particular brake booster or master cylinder. Generally, you will want to make sure that there is not any tension on the master cylinder pushrod when it is at rest, with a small amount of free play at the brake pedal pad.

Step 9: Adjust the brake light switch.

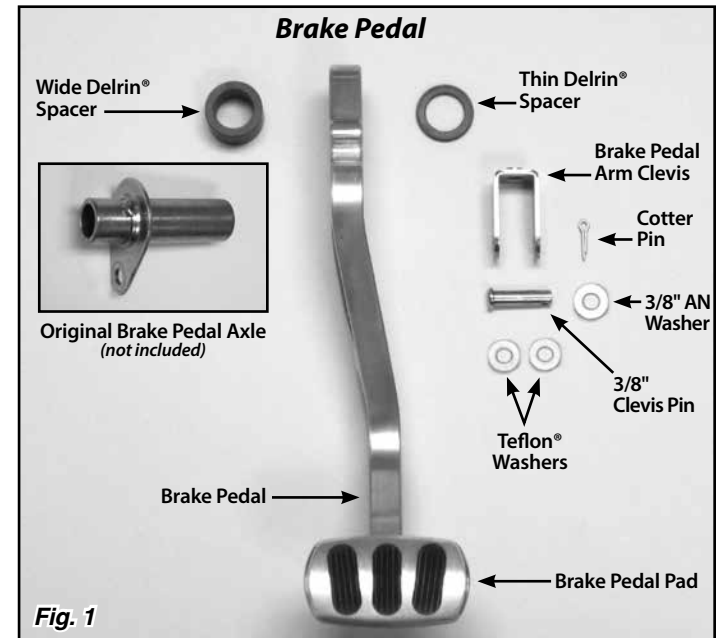

Fig. 1

1955-1957 Chevy Brake and Clutch Pedal Installation Instructions

Clutch Pedal:

Refer to Fig. 5 for the component names.

Step 1: Install the brake pedal first. Follow the instructions above, but **do not use your original brake pedal axle**. Install the new Lokar clutch pedal axle housing instead.

Step 2: Coat the inside and outside surfaces of the nylon bushings with a thin film of grease. Slide the nylon bushings into both ends of the clutch pedal axle housing.

Step 3: Insert the splined shaft into the clutch pedal axle housing, with the long splines on the left and the short splines on the right. Push it through so that the splined ends are protruding from both sides of the pedal support bracket. Fig. 6

Step 4: Install the clutch pedal onto the left hand end of the splined shaft. Install the 1/4"-20 x 1/2" flat head bolt and the aluminum end washer onto the left hand end of the splined shaft. Fig. 7

Step 5: Remove the clutch spring bracket from your original clutch pedal. Install it onto the new Lokar clutch pedal, using the provided 3/8"-24 x 1-1/2" hex head bolts with flat washers and nylock nuts. On 1955-56 models, the clutch spring bracket bolts to the left side of the clutch pedal. On 1957 models, the clutch spring bracket bolts to the right side of the clutch pedal. Consult the correct year factory service manual for diagrams if needed.

Step 6: Install the clutch pedal spring. If you have difficulty getting the clutch pedal spring installed, it may be helpful to temporarily loosen the clutch spring bracket on the pedal and remove one of the bolts. That will allow the bracket to pivot upwards. Depressing the pedal to the floor when attaching the clutch pedal spring may also help. Make sure you reinstall and/or tighten the 3/8"-24 x 1-1/2" hex head bolts once the clutch pedal spring is connected.

Step 7: Connect the clutch lever arm to the original clutch pushrod (not included) using a 5/16" flat washer, the coil spring, another 5/16" flat washer, and small cotter pin as shown in Fig. 8. Then install the clutch lever arm onto the right hand end of the splined shaft. Install the 1/4"-20 x 1/2" flat head bolt and aluminum end washer onto the right hand end of the splined shaft. Tighten the 1/4"-20 x 7/8" socket head bolt in the clutch lever arm to clamp it into place. Fig. 9

Step 8: Adjust the clutch linkage, following the procedure in the factory service manual for your particular model of car. There should be approximately 3/4" - 1" of pedal free travel (measured at the clutch pedal pad) before the release bearing contacts the pressure plate fingers. It may be necessary to reposition the clutch pedal or the clutch lever arm on the splined shaft in order to get the clutch linkage adjusted correctly.

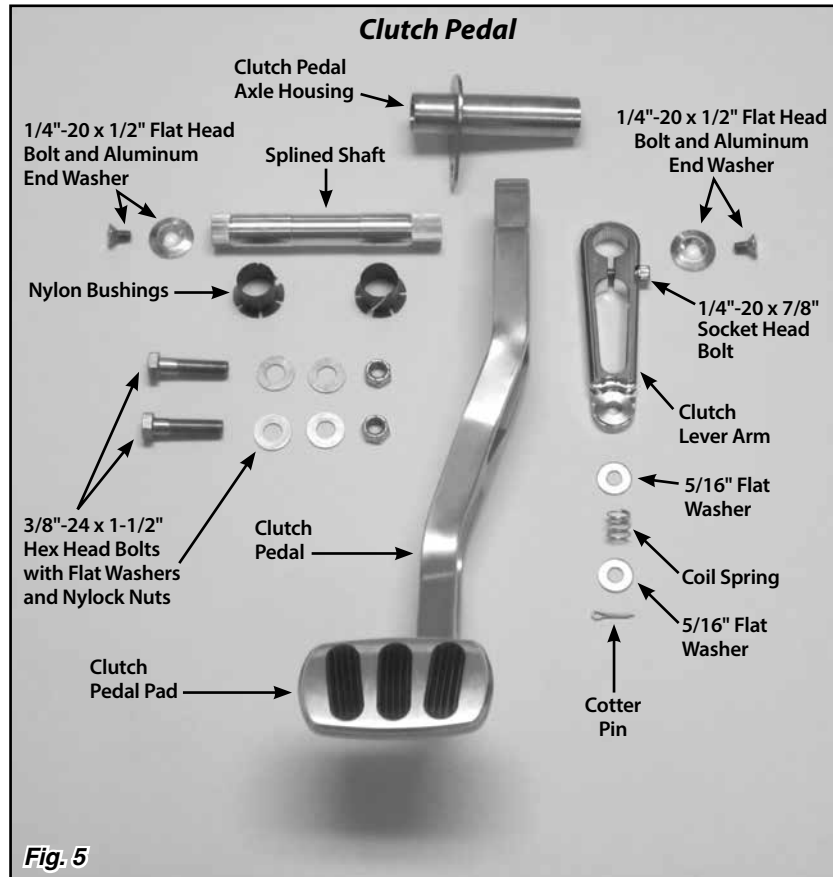

Fig. 5

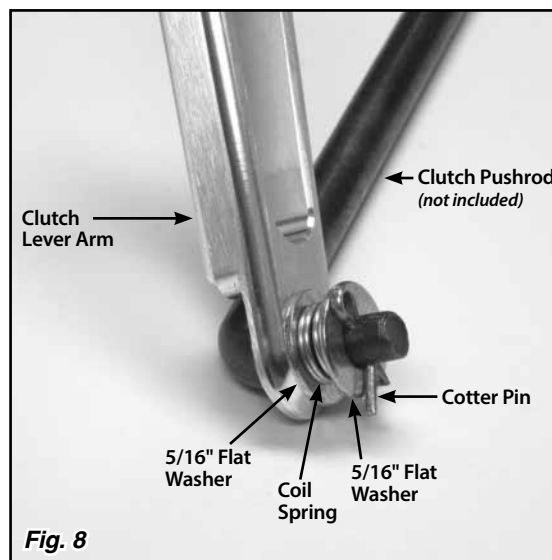

Fig. 8

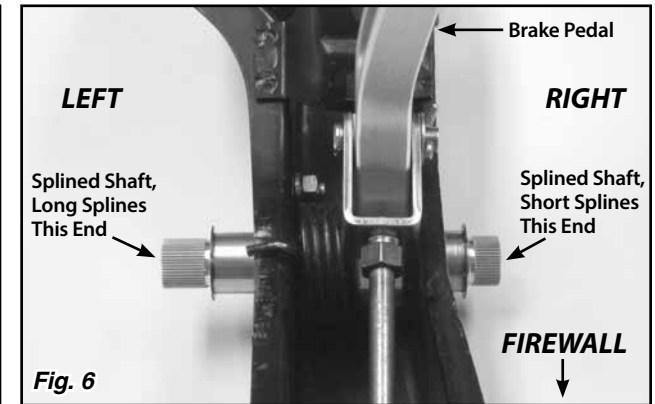

Fig. 6

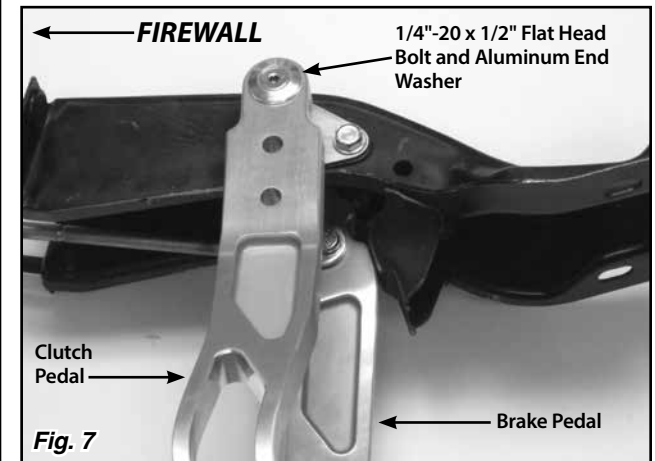

Fig. 7

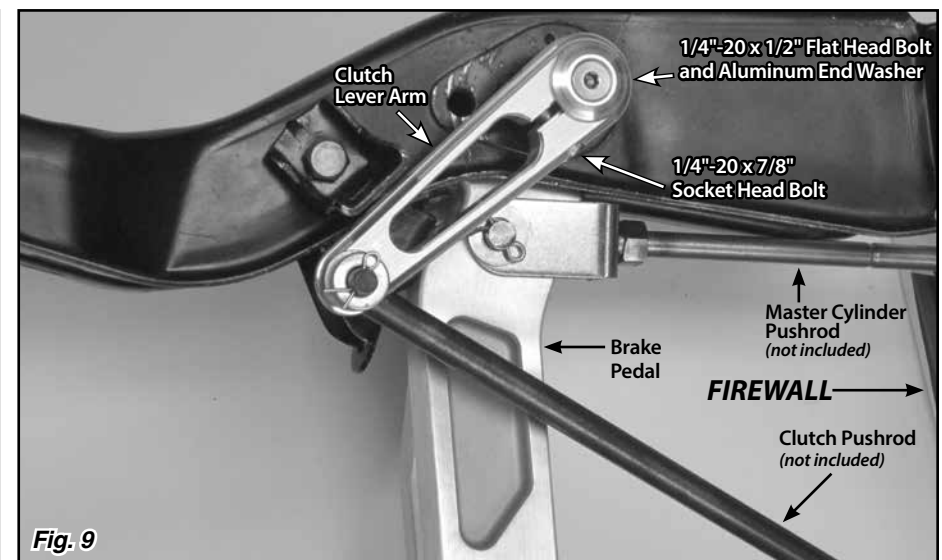

Fig. 9